

# Pressure relief valves SDD 910



- All wet parts in plastic
- Protection of pumps and piping
- Body: PPG or PVDF
- Unions: PVC, PP or PVDF
- ND 10 and ND 15
- Adjustable trigger point: 0.5 ... 6 bar

## FUNCTION AND INSTALLATION

Pressure relief valve SDD 910 protects a network of pipes in the event of overpressure that could lead to deterioration of the system. It limits the static pressure to a constant upstream pressure when the pressure is over the settled value.

All wet parts are of plastics. The diaphragm and seals are of EPDM or FPM according the model.

SDD 910 valves may be used as pressure relief valves on dosing or volumetric pumping systems.

The pressure relief valves are mounted in any position, or in line or as a bypass, according to requested operation.

They can also be used on injection stems with dosing pumps, avoiding the risk of siphoning, creating a constant back-pressure (adjustable on site).

As a standard supply, valves SDD 910 have a top handle for adjustment, which is self-locking.

(No needs of tools)



## TECHNICAL FEATURES

Body	PPG (glass fibre reinforced polypropylene) or PVDF
Diaphragm	EPDM or FPM
Seals (unions)	EPDM or FPM
Upper cover	PPG
Adjusting knob	PPG
Screws	Stainless steel
Spring	Stainless steel
Insert (movement inside)	Brass
Dimensions	ND 10 or ND 15
Hysteresis	About 0.3 bar
Adjustment range	0.5 ... 6 bar
Fittings	PVC Unions for solvent welding; PP or PVDF Unions for fusion welding

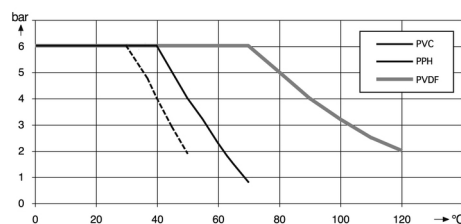

Diagram: Pressure vs. Temperature

# BAMO INTERNATIONAL

22, Rue de la Voie des Bans · Z.I. de la gare · 95100 ARGENTEUIL

Tel +33 (0)1 30 25 83 20 Web [www.bamo.eu](http://www.bamo.eu)

Fax +33 (0)1 34 10 16 05 E-mail [export@bamo.fr](mailto:export@bamo.fr)

Pressure relief valves  
**SDD 910**

28-10-2019

D-910.01-EN-AA

PLAS

910-01 /1

## CODE NUMBERS, DIMENSIONS

Code	ND	Body / Unions	Seal & diaphragme	L	H	d	h	L1	Z
910 001	10	PPG / PVC	EPDM	124.5	89	16	18	91	97.5
910 002	15	PPG / PVC	EPDM	128	89	20	23	91	98
910 011	10	PPG / PVC	FPM	124.5	89	16	18	91	97.5
910 012	15	PPG / PVC	FPM	128	89	20	23	91	98
910 101	10	PPG / PP	EPDM	124.5	89	16	18	91	97.5
910 102	15	PPG / PP	EPDM	128	89	20	23	91	98
910 111	10	PPG / PP	FPM	124.5	89	16	18	91	97.5
910 112	15	PPG / PP	FPM	128	89	20	23	91	98
910 211	10	PVDF / PVDF	FPM	124.5	89	16	18	91	97.5
910 212	15	PVDF / PVDF	FPM	128	89	20	23	91	98

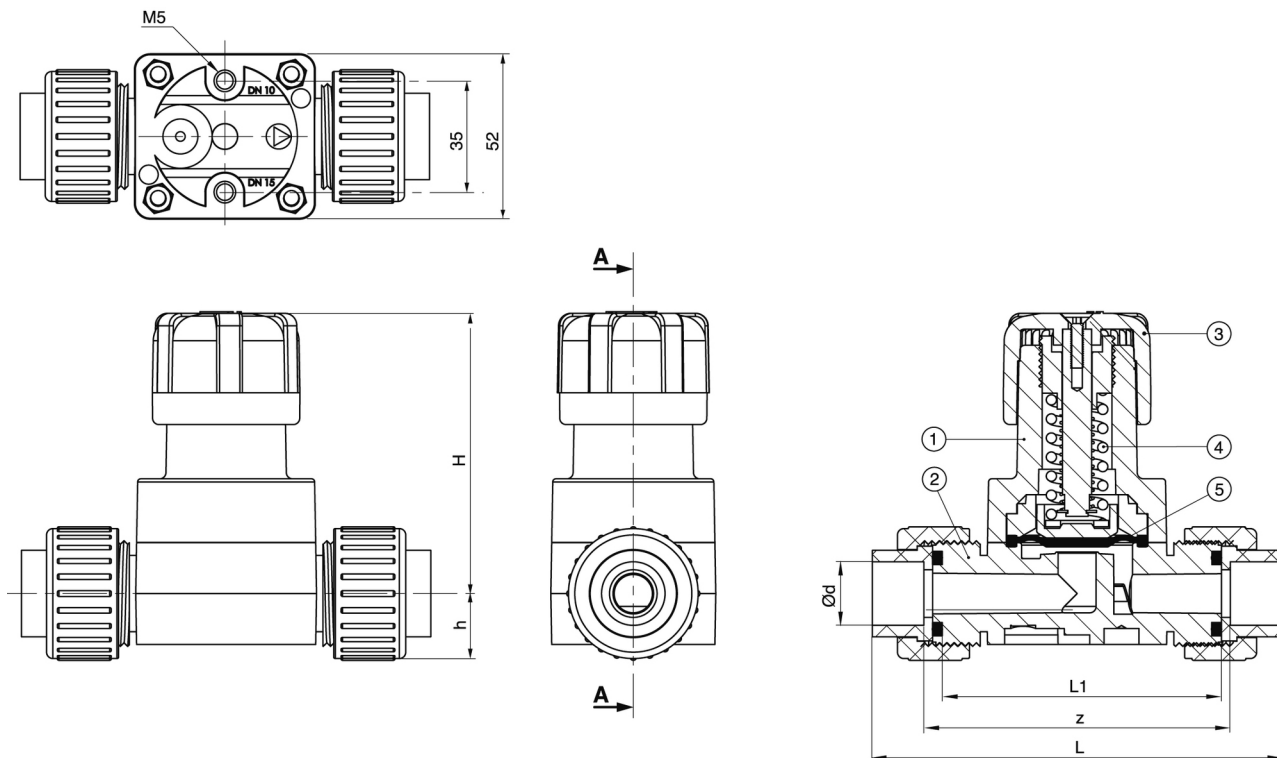

(1)	Bonnet in PPG (PP fiber-glass reinforced)
(2)	Body or in PPG or in PVDF
(3)	Adjustment knob in PPG
(4)	Spring in stainless steel
(5)	Diaphragm in EPDM or FPM

## FLOW FEATURES

ND	Flow rate l/h*	Kv (l/h)**	*: Maximum flow rates for a speed of 3 m/second; **: Values for water at 20 °C <i>This speed is a maximum not to exceed with plastic materials. Beyond, the valve deteriorates quickly.</i>
10	900	1920	
15	2000	2560	

**BAMO** INTERNATIONAL

22, Rue de la Voie des Bans · Z.I. de la gare · 95100 ARGENTEUIL  
 Tel +33 (0)1 30 25 83 20 Web [www.bamo.eu](http://www.bamo.eu)  
 Fax +33 (0)1 34 10 16 05 E-mail [export@bamo.fr](mailto:export@bamo.fr)

Pressure relief valves  
**SDD 910**

28-10-2019

D-910.01-EN-AA

PLAS

910-01/2